

Preparation

Part Number: PT611-30130-XX**Kit Contents**

Item #	Quantity Reqd.	Description
1	1	Trunk Lid Spoiler

Hardware Bag Contents

Item #	Quantity Reqd.	Description
1	2	Nut, 10 mm

Additional Items Required For Installation

Item #	Quantity Reqd.	Description
1	1	PT611-30130 Spoiler Install Kit

Conflicts

GS F

Recommended Tools

Personal & Vehicle Protection	Notes
Safety Glasses	
Blankets	
Wrist & Belt Protectors	
Masking Tape	2"
Special Tools	Notes
None	
Installation Tools	Notes
Socket	10 mm – ¼" Drive
Ratchet	
Panel Clip Removal Tool	e.g. Panel Pry Tool #1 Toyota SST # 00002-06001-01
Center Punch	
Twist Drill Bit	3mm or 1/8in and 10mm or 3/8in
Drill Motor	½"
Torque Wrench	0-100 lbf-in
Hex Nut Driver	10 mm
Drill Stops	
Shop Vacuum	
Hole Deburring Tool	
Magnet with Flex Shaft	
Small Parts Bin	
Extension	6" - ¼" Wobble
Special Chemicals	Notes
Cleaner	3M™ Prep Solvent 70
Sealant	3M Ultra-Pro Body Sealant

NOTE: Part number of this accessory may not be the same as the part number shown.

General Applicability

2013 and newer GS models

Recommended Sequence of Application

Item #	Accessory

*Mandatory

Vehicle Service Parts (may be required for reassembly)

Item #	Quantity Reqd.	Description

Legend

STOP: Damage to the vehicle may occur. Do not proceed until process has been complied with.



OPERATOR SAFETY: Use caution to avoid risk of injury.



CAUTION: A process that must be carefully observed in order to reduce the risk of damage to the accessory/vehicle and to ensure a quality installation.



TOOLS & EQUIPMENT: Used in Figures calls out the specific tools and equipment recommended for this process.



REVISION MARK: This mark highlights a change in installation with respect to previous issue.



SAFETY TORQUE: This mark indicates that torque is related to safety.

Care must be taken when installing this accessory to ensure damage does not occur to the vehicle. The installation of this accessory should follow approved guidelines to ensure a quality installation.

These guidelines can be found in the "Accessory Installation Practices" document.

This document covers such items as:-

- Vehicle Protection (use of covers and blankets, cleaning chemicals, etc.).
- Safety (eye protection, rechecking torque procedure, etc.).
- Vehicle Disassembly/Reassembly (panel removal, part storage, etc.).
- Electrical Component Disassembly/Reassembly (battery disconnection, connector removal, etc.).

Please see your LEXUS dealer for a copy of this document.

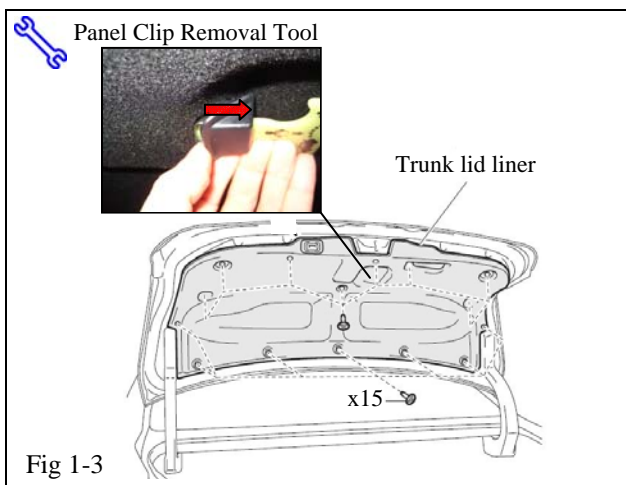
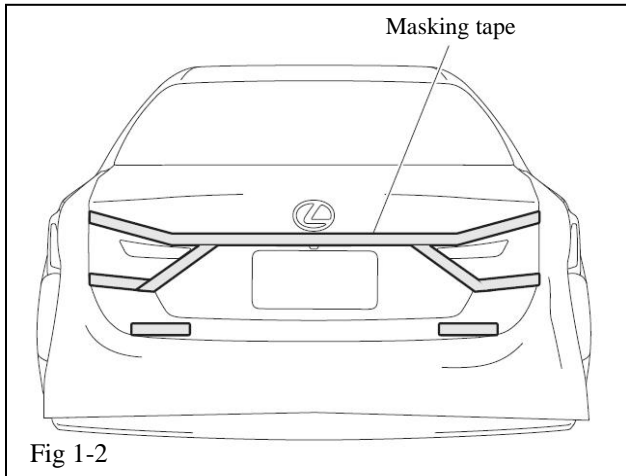
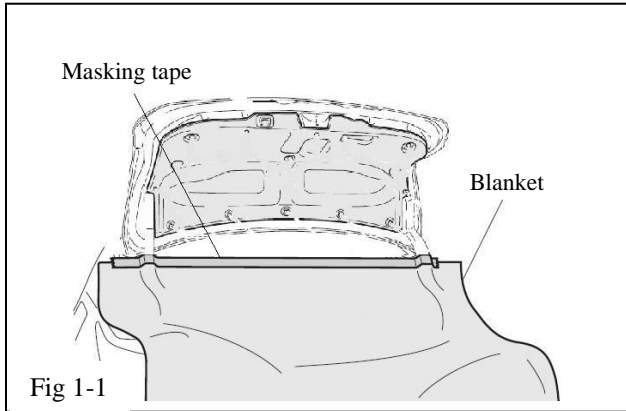

1. Vehicle Preparation.

- (a) Installation of the Deck Lid Spoiler should not take place until the following have been met:
 - (1) Car wash completed.
 - (2) Vehicle and Parts are at least 60 degrees Fahrenheit. Use a heat strip to warm body if necessary.
- (b) Open the trunk lid and place blankets inside the trunk and around the trunk opening. Apply masking tape to the trunk lid surface in the area of the emblems and tail light gaps. (Fig 1-1, 1-2)
- (c) Remove the emergency release handle cover by unsnapping it and pulling it forward in the direction of the handle. (Fig 1-3)
- (d) Using Panel Clip Removal Tool, remove the fifteen (15) exposed push pins that attach the trunk lid liner. (Fig 1-3)
- (e) Carefully remove the trunk liner. The trunk liner and push pins will be saved for re-installation.



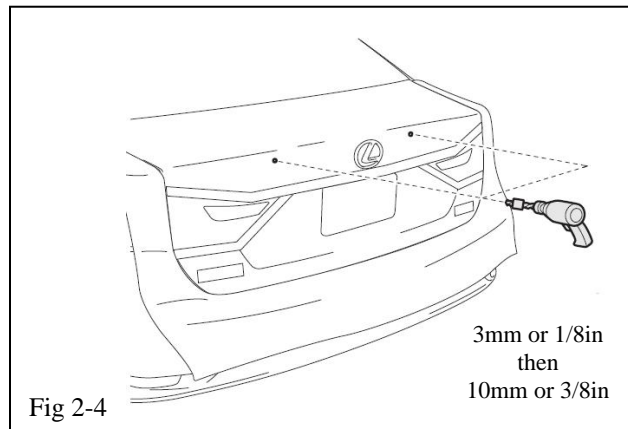
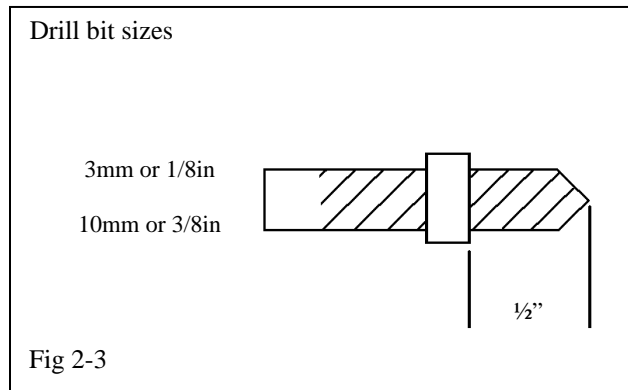
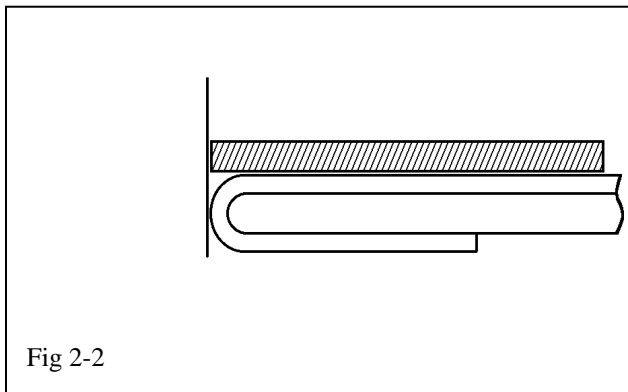
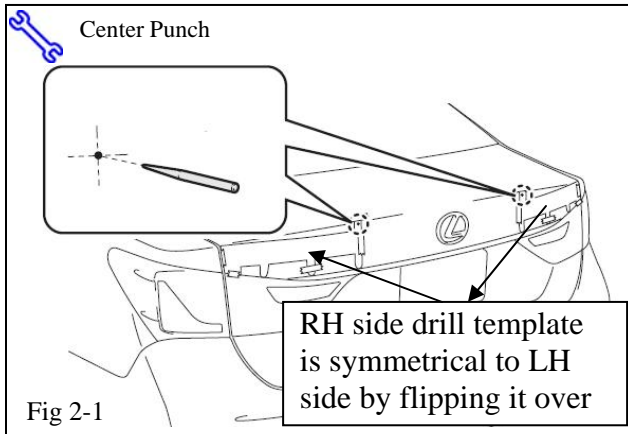

2. Using the Drill Template

- +** (a) Eye protection must be worn during all hole drilling.
- (b) Place the Drill Template onto the trunk lid of the vehicle and mark the two (2) hole center with a center punch . (Fig 2-1)



Note: Confirm the template is flat, smooth and properly aligned with the edges of the trunk lid and tape as indicated on the template.

Template is designed to align to the right edge of the trunk lid.

Flip the template over to locate left drill location. (Figs 2-1 & 2-2)

⚠ CAUTION: Be careful not to cut or damage the wire harness which pass through the trunk lid.

- (c) Set the drill bit depths as shown. (Fig 2-3)
- (d) Using the 3mm or 1/8in bit, drill a pilot hole at the two (2) locations. (Fig 2-4)
- (e) Using the 10mm or 3/8in bit, drill the same two (2) locations to the final hole size.
- (f) Carefully vacuum the trunk surface and the surrounding area of drilling debris. Use a magnet with a flexible shaft to remove any remaining chips.

- (g)  Debur all previously drilled holes.
- (h) Grab the trunk lid and with an up and down motion, vigorously shake the trunk lid to dislodge any metal chips remaining from the drilling process. Use a magnet with a flexible shaft to remove any remaining chips.
- (i) Vacuum any drill shavings from the trunk lid and remove the blankets and masking tape.
- (j)  The trunk lid where the spoiler attaches must be cleaned with 3M™ Prep Solvent 70 and a lint free cloth.

NOTE: When cleaning with 3M™ Prep Solvent 70 follow manufactures directions. Do not allow cleaner to air dry.

- (k) After cleaning, carefully apply 3M™ Ultra-Pro Body Sealant to all drilled hole edges.

3. Deck Lid Spoiler Installation.

- (a) Affix spoiler onto trunk lid by applying masking tape on the edges of the spoiler ensuring that the upper and lower gaps are even as shown. (Fig 3-1)
- (b) Using your fingers, center the spoiler side to side on the trunk lid.

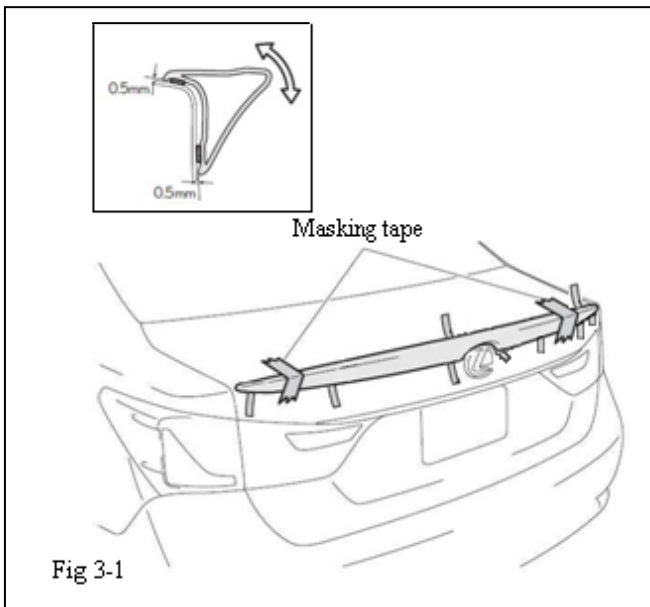

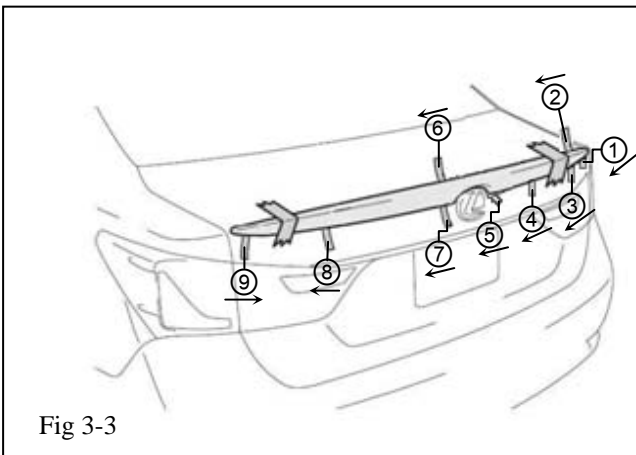
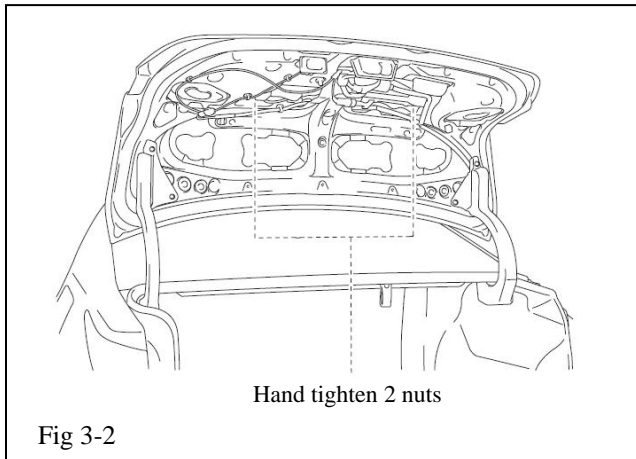

- (c) Loosely hand tighten the two (2) 10mm nuts on to the studs from the inside of the trunk lid. (Fig 3-2)
- (d) Ensuring that the upper and lower gaps are even and the spoiler is centered on the trunk lid. Remove masking tape and affix spoiler by pulling on the pull tabs in the directions shown. (Fig 3-3)

(1) Pre-pull each of the nine (9) pull tab liners and lightly rest them back over the tape prior to installing the spoiler to facilitate the removal of the tape liners in the following step.



(2) Remove the pull tab/liners in the sequence shown in figure 3-3, starting with “①” through “⑨” pulling the tabs in the directions indicated by the arrows.

(3) Do not apply pressure to the spoiler as the tape liners are removed so the tape liners do not get trapped between the spoiler the trunk. If needed, slightly lift on the spoiler to free the tape liner and remove it.

CAUTION: Take care when pulling the tape liner from the spoiler edges to prevent tearing of the tape liner.

(4) Once all tape liners have been removed, press down on the spoiler to fully adhere the tape to the trunk lid surface.

- (e) Open the trunk lid and torque nuts in Fig 3-2 to 70 lbf-in (7.9 Nm).
- (f) Re-install trunk liner back into position and re-install the fifteen (15) push pins.
- (g) Clean off remaining fingerprints on the spoiler and the trunk lid.

Checklist - these points **MUST** be checked to ensure a quality installation.

Check:

Look For:

Accessory Function Checks

- Check for full tape adhesion.

- Verify spoiler side to side alignment.

Full adhesion with no gaps.

+/- 2mm with respect to left and right side.

Vehicle Function Checks

- Verify Emergency Trunk Release Handle operation.

Emergency Trunk Release Handle operates correctly. (With the trunk lid in the open position, trip the trunk lock closed using a nylon pry tool. Pull the emergency trunk release handle and verify the trunk lock has opened.)